



Radhvi Engineering LLP

**Manufacturer of Goods Lift, Scissor Lift, Lifter, E.O.T Crane
Industrial Tin Shed Fabrication All kind of Industrial Fabrication**



Goods Lift



Scissor Lift



**Hand Pallet
Truck**

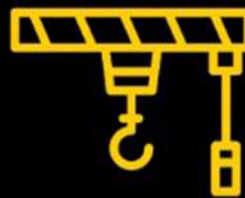

E.O.T Crane



Industrial Tin Shed

✉ radhviengineering@gmail.com

☎ 95996-75875

📍 **Office Address** - Plot no- A-189, Gulab Bagh, Uttam Nagar, Delhi-110059

🏭 **Factory Address** - Plot no 1109, Shed No-02, Village- Tigaon (Achpalgarh), Near Shiv Bed College, Tigaon Road, Faridabad, Haryana 121101

☎ 95996-75875

✉ radhviengineering@gmail.com

Radhvi Engineering LLP

Single Mast Single Cylinder Goods Lift

- Works on Hydraulic Fluid.
- Low Maintenance.
- Rough & Tough Used.
- Load Capacity- 800 kg
- Easy Installation.
- Lift size can be customized as per customer requirement





Double Cylinder Double Mast Lift

- Works on Hydraulic Fluid
- Rough & Tough Used
- Easy Installation
- Loading Capacity up to 2000 kg
- Low Maintenance.
- Improved Load Control
- Lift size can be customized as per customer requirement

☎ 95996-75875

✉ radhviengineering@gmail.com

Radhvi Engineering LLP

95996-75875

radhviengineering@gmail.com

Radhvi Engineering LLP

Double Cylinder Double Mast Lift

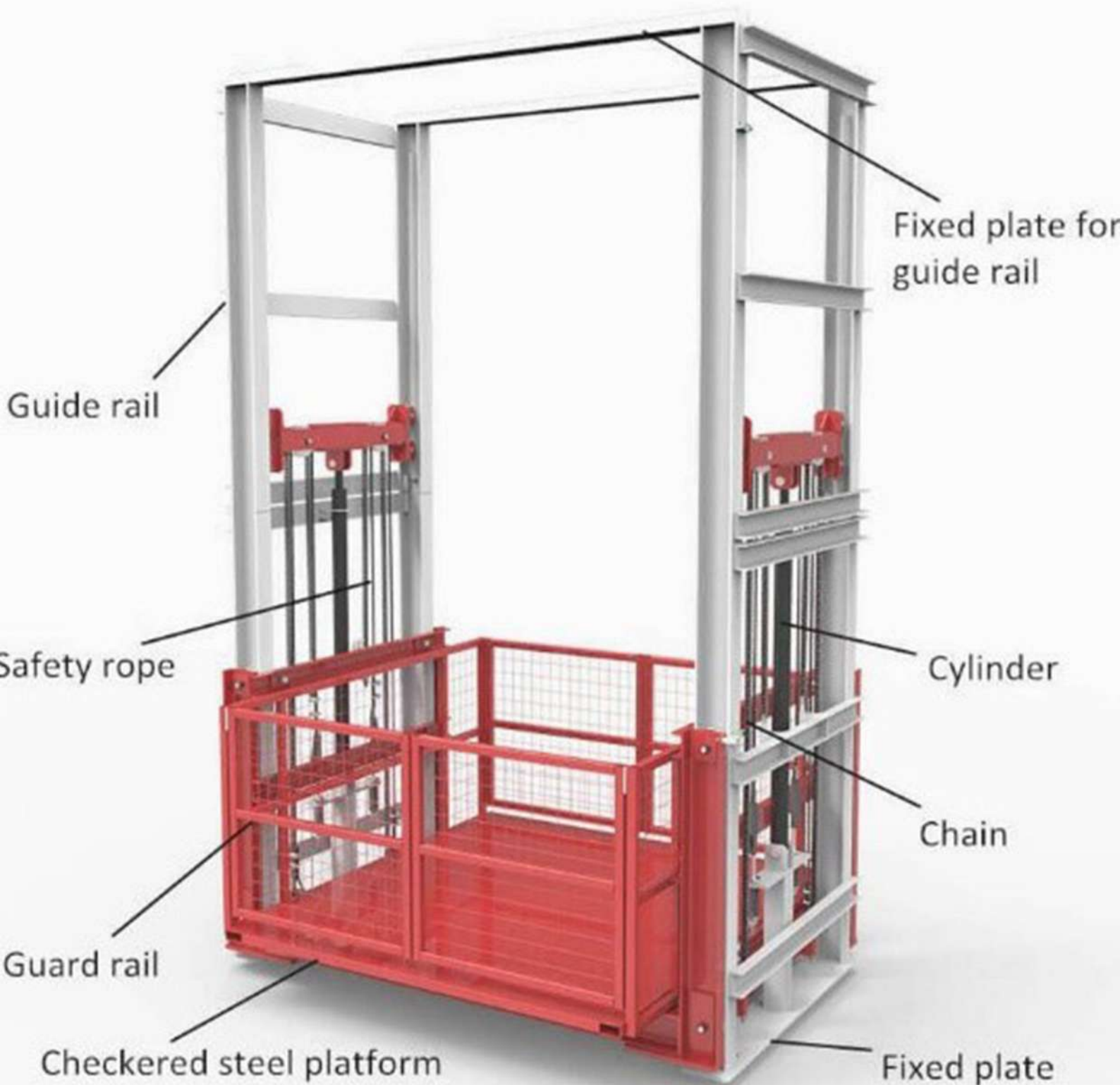

☎ 95996-75875

✉ radhviengineering@gmail.com

Radhvi Engineering LLP

Scissor Lift

- Work on Hydraulic Fluid.
- Easy Maintenance
- Lift Height can be customised
- Load capacity- 500 kg to 3000 kg





Industrial Tin Shed

Tin sheds can be used for Factory, warehouses, green houses, community halls and canopy etc. These Tin Sheds are different from conventional buildings in ways like speed in delivery and erection, flexibility in expansion and withstand severe weather conditions.

Maintenance Free

➤ Long Life

 95996-75875

 radhviengineering@gmail.com

Radhvi Engineering LLP

☎ 95996-75875

✉ radhviengineering@gmail.com

Radhvi Engineering LLP

EOT Crane-Electric Overhead Travelling

EOT cranes are extensively used in warehouses and industry. An EOT crane is able to carry heavy objects to anywhere needed on the factory floor, and can also be used for lifting.

Advantages of an EOT Crane

- Reduced Floor Obstructions
- Greater Floor Coverage
- Easy and Effective handling
- Improved Load Control
- Economical
- Features
- Operational Safety
- Highly Customized
- The crane is easy to operate, crane operators only need short training on how to operate EOT crane



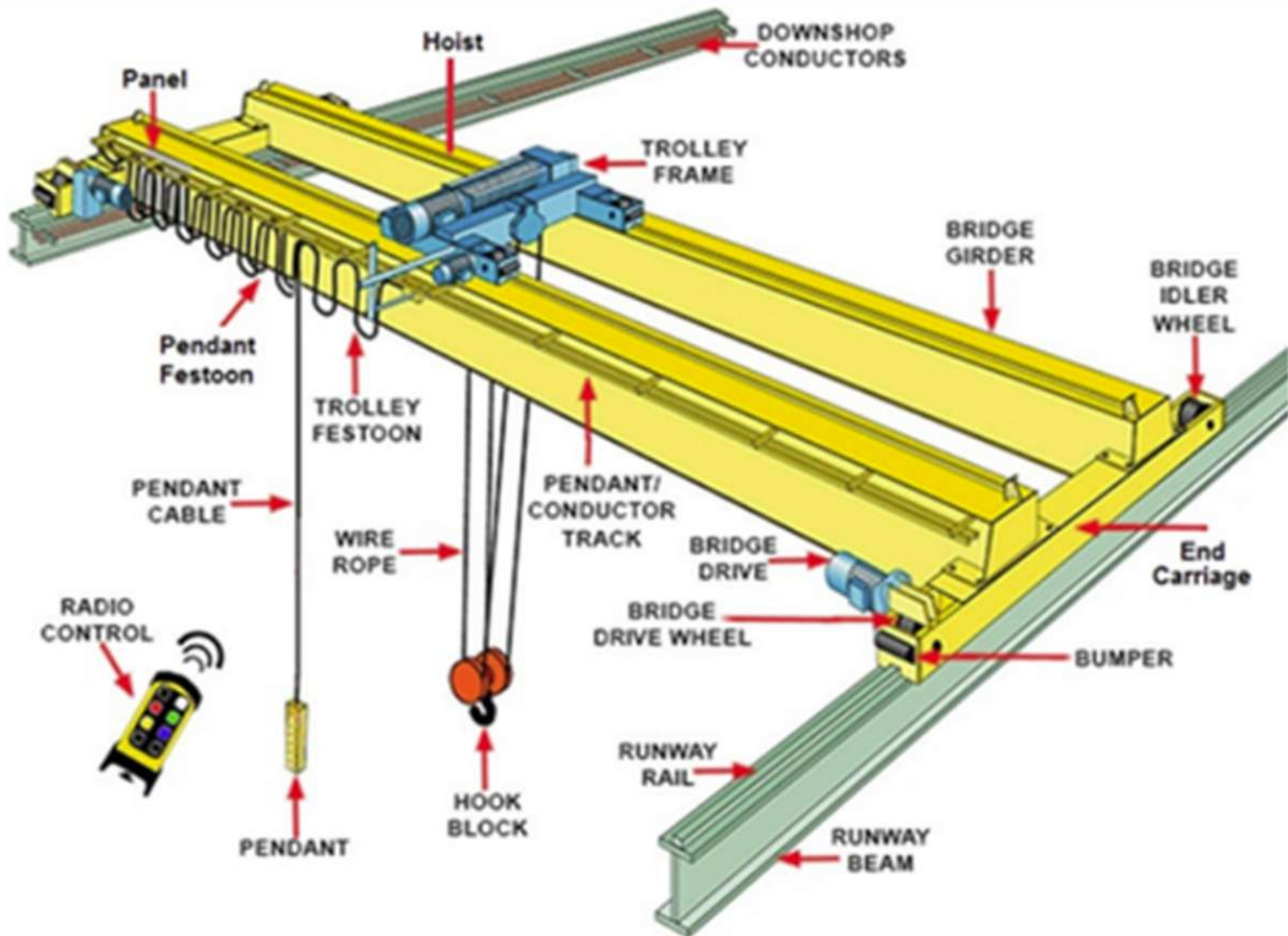

EOT Crane-Electric Overhead Travelling Crane

☎ 95996-75875

✉ radhviengineering@gmail.com

Radhvi Engineering LLP



Jib Crane

- Generally used in building construction for lifting stone, sand, Cement.
- Load Capacity- 500 kg

Hand Lifting Table

Works on hydraulic Fluid

Lifting height – 3-4 ft (can be customised)

Load Capacity- 250 kg





Hand pallet Truck

- Hand pallet trucks are customisable, making them suitable for a broad range of material handling applications, including horizontal transport, order picking, loading / unloading and stacking.

Industrial trolley

- Trolley is the device used for carrying load or to transport the material from one point to another.
- Size can be customized according to requirement.



☎ 95996-75875

✉ radhviengineering@gmail.com



Structure for lift

Structure is used in open area for supporting Lift Mast.

☎ 95996-75875

✉ radhviengineering@gmail.com

Radhvi Engineering LLP



Radhvi Engineering LLP

Moblie - 95996-75875

Email - radhviengineering@gmail.com

GST No- 07ABEFR2958P1ZH

Office Address - Plot no- A-189, Gulab Bagh,
Uttam Nagar, Delhi- 110059

Factory Adress - Plot no 1109, Shed No-02,
Village- Tigaon (Achpalgarh), Near Shiv Bed
College, Tigaon Road, Faridabad, Haryana
121101